



UNIVERSITY COLLEGE TATI (UCTATI)

FINAL EXAMINATION QUESTION BOOKLET

COURSE CODE : BMT 4043

COURSE : AUTOMATION ENGINEERING TECHNOLOGY

SEMESTER/SESSION: 1 - 2024/2025

DURATION : 3 HOURS

Instructions:

1. This booklet contains 4 questions. Answer **ALL** questions.
2. All answers should be written in answer booklet.
3. Write legibly and draw sketches wherever required.
4. If in doubt, raise your hands and ask the invigilator.

DO NOT OPEN THIS BOOKLET UNTIL YOU ARE TOLD TO DO SO

THIS BOOKLET CONTAINS 8 PRINTED PAGES INCLUDING COVER PAGE

QUESTION 1

- a) i) Explain five (5) characteristics of compact PLC (10 marks)
 ii) Explain five (5) characteristics of modular PLC (10 marks)

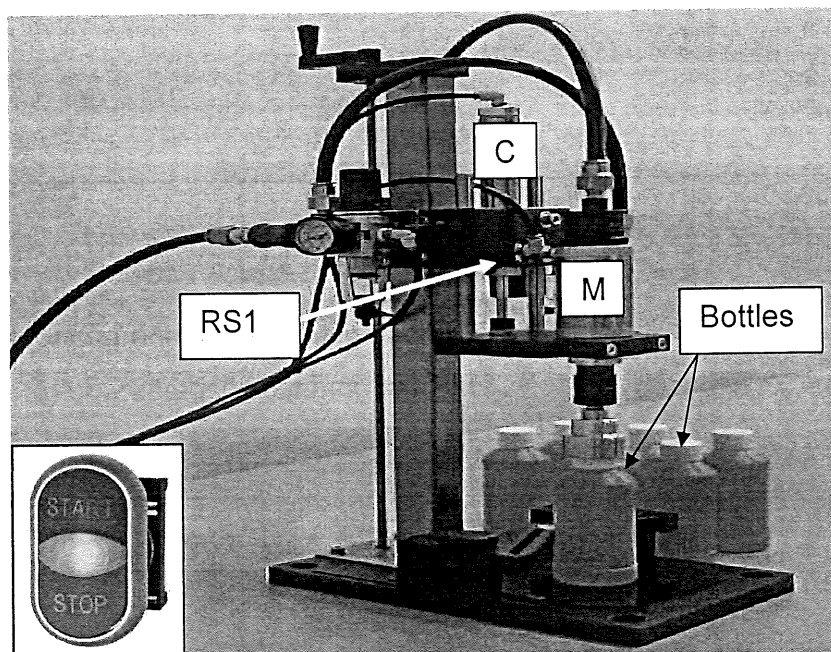

Figure 1

- b) Figure 1 show bottle cap tightening machine, when the start switch is activated Cylinder (C) will extend, pneumatic motor (M) is used to rotate the bottle cap to tighten the bottle during Cylinder (C) extends fully, confirm by reed sw1 (RS1). This pneumatic motor is connected to the shaft cylinder (C). When the Stop switch is pressed all machine operations will stop immediately.

Hint: 5/2way single solenoid and 3/2 way single solenoid valve should be used

- i) State all the component to be used (2 marks)
 ii) Produce a PLC program for the above problems. (5 marks)
 iii) Explain the circuit and PLC operation (6 marks)

QUESTION 2

- a) State three (3) **SFC** (Sequence Function Chart) components: (6 marks)
- b) Explain the function of **Jump Instruction** in PLC, a program diagram can be used to explain an example of its function. (6 marks)
- c) Figure 2 shows a warehouse whose entry is fully automatically controlled by a PLC system. When sensor 1 detects the presence of a truck, the door will open, when sensor 2 detects a truck leaving (away) the door, the system will allow the door to cover the warehouse without accident occurring, Sensor 3 and sensor 4 are tasked with detecting if the door has reached the full opening limit (sensor 3), while sensor 4 detects the door limit is fully closed. (DIFU , DIFD application)

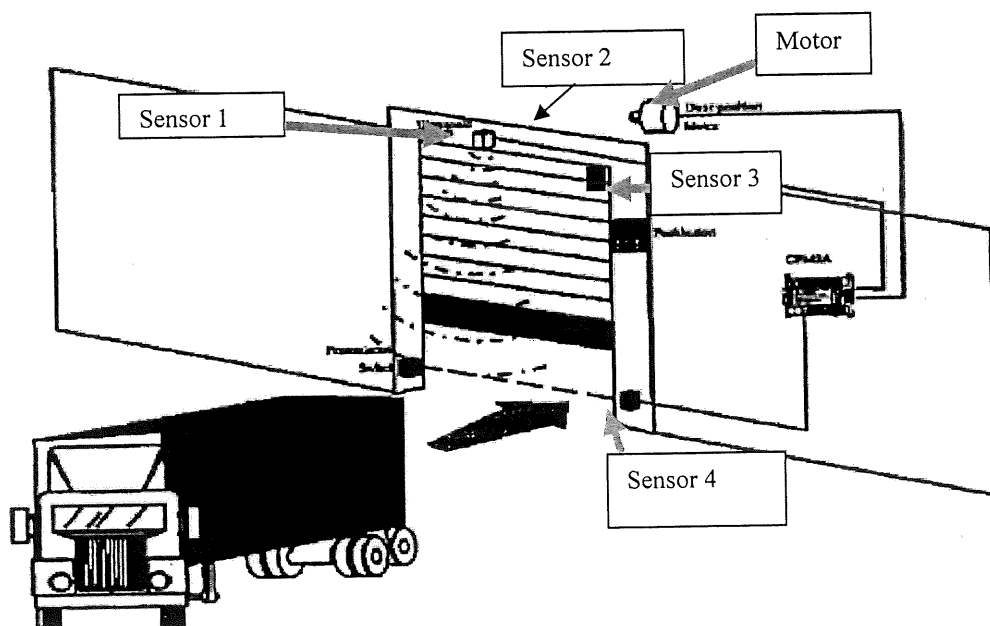

Figure 2

AUTOMATION ENGINEERING TECHNOLOGY (BMT 4043)

- i) State all the component to be used (2 marks)
- ii) Produce a PLC program using DIFU and DIFD for the above problems. (5 marks)
- iii) Explain the circuit and PLC operation (6 marks)

QUESTION 3

- a) i) Describe the Interlock Instruction function, a program diagram can be used to explain an example of its function. (8 marks)
- ii) What is meant by PID Module, explain in detail. (8 marks)
- b) Figure 3 shows, the piston rod of a double acting cylinder 1 is to extend, when three of normally open pushbuttons (**PB1 AND PB2 AND PB3**) are actuated and will only retract when the fully extend position of a double acting cylinder is reached, which detected by a normally open Roller Limit switch (**RLSW1**) **AND**, after **20 seconds** extension of fully extension of cylinder.

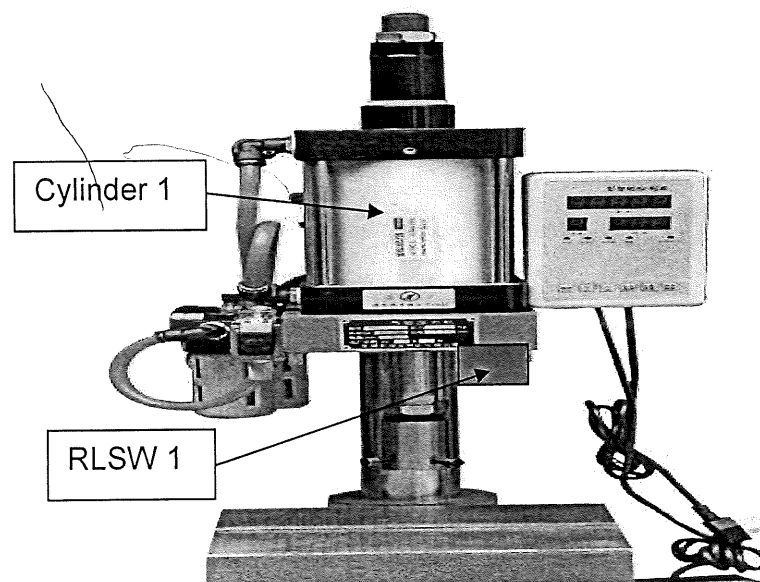

Figure 3

Hint: 5/2 way double solenoid valve should be used

- i) State all the component to be used (2 marks)
- ii) Produce the **SFC** Method of PLC program for the above problem. (5 marks)
- iii) Explain the circuit and PLC operation (6 marks)

QUESTION 4

- a) Explain the description of Omron **Shift Register**, as it is used in PLC. (4 marks)
- b) Figure 4 displays an automatic filling and labeling machine that consists of 4 steps. First we verify the bottle is in good condition. Next we fill in water inside the bottle. Then we place a bottle sealer and finally we eject the completed bottle to the next station. If the bottle is in bad condition, we need to reject it. Therefore we need to track the bad bottle in the process line so that we can tell the system not to do each task. We use a sensor to look at the bottle condition. An encoder tracks the bottle going along the conveyor.
- i) Produce a PLC program using Shift Register for the above problems. (5 marks)
- ii) Explain the circuit and PLC operation (4 marks)

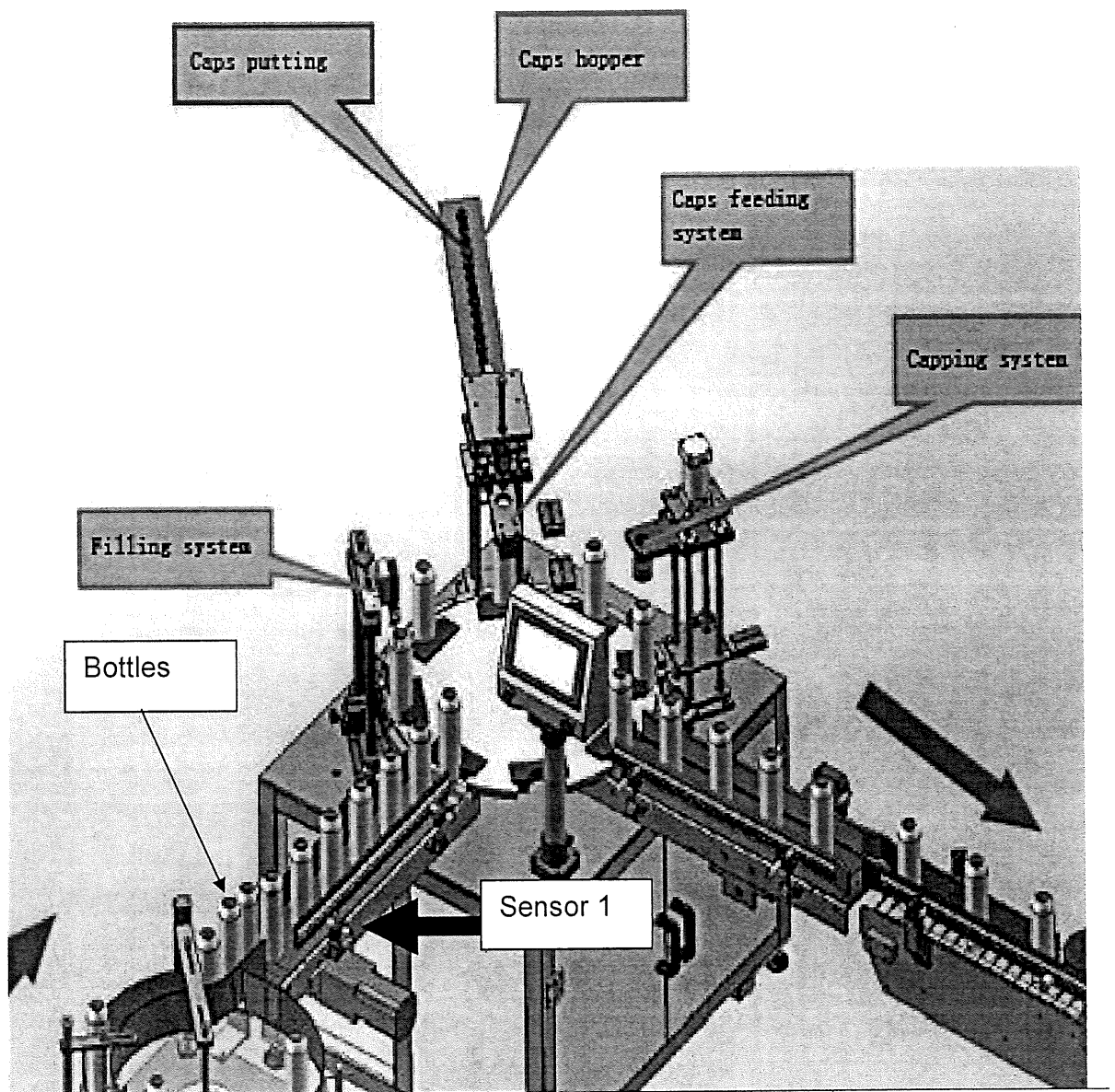

Figure 4

-----End of Question -----

AUTOMATION ENGINEERING TECHNOLOGY (BMT 4043)

ATTACHMENT:

